

## Contents: Series 33 (3-Way), 43 (4-Way), 53 (5-Way) MULTI-PORT BALL VALVES

BRIEF INTRODUCTION .....	2
INSTALLATION .....	2
Installation of Threaded End Valves.....	2
(33-TH/43-TH/53-TH).....	2
Installation of Welded End Valves .....	2
(33-SW/43-SW/53-SW OR 33-BW/43-BW/53-BW).....	2
Installation of Flanged End Valves.....	2
(33-F1/43-F1/53-F1 OR 33-F3/43-F3/53-F3) .....	2
Installation of Hygenic Clamp/Sanitary Ends.....	2
(33-SA/43-SA/53-SA OR 33-SF/43-SF/53-SF) .....	2
OPERATION.....	2
Automation Operation .....	3
MAINTENANCE .....	3
Table 1: Body Bolt Torque .....	3
Table 2: Stem Nut Torque.....	4
Seat Kit & Repair Kit Part Numbers.....	4
Materials List .....	6

## BRIEF INTRODUCTION

A-T Controls Multi-Port high performance ball valves have been designed and engineered with five seats for equal loading and sealing at any port to provide long lasting and trouble free service when used in accordance with the instructions and specifications stated in this document.

---

### !!!WARNING!!!

---

**FOR YOUR SAFETY, IT IS IMPORTANT THAT THE FOLLOWING PRECAUTIONS BE TAKEN BEFORE REMOVAL OF THE VALVE FROM THE LINE OR ANY DISASSEMBLY.**

1. Wear protective clothing and equipment when working with potentially harmful fluids.
2. **Depressurize the line and cycle the valve as follows:**
  - a. Place the valve in the open position and drain the line.
  - b. Cycle the valve to relieve residual pressure in the body cavity before removal from the line.
  - c. Allow valve to cool if valve is used in high temperature applications.
  - d. After removal and before any disassembly, cycle the valve again several times to relieve extra trapped fluids or gases.

---

## INSTALLATION

The 33, 43, 53-series valve must be installed according to proper flow pattern to achieve correct fluid flow path. To prevent damage to the seats and ball surface, the pipeline must be flushed free of dirt, burrs, and welding residues before installing the valve. The pipe must be free from tension and in proper alignment.

### Installation of Threaded End Valves (33-TH/43-TH/53-TH)

- 1.1. When installing or removing threaded piping from the valve, place a wrench on the body or the end cap nearest the end being worked on. Make certain the end cap of the valve does not turn the valve body. (Body/end cap joint is a right hand thread.)
- 1.2. Threaded ended valves have NPT threads.
- 1.3. On threaded lines, valve can be assembled without the use of unions.
- 1.4. To insure a leak tight fit, moderate use of a compatible pipe joint compound is necessary.
- 1.5. Apply pipe wrench on the end cap of the ball valve

only when tightening. Tightening by using the valve body or handle can seriously damage the valve.

**NOTE:** Prior to welding or brazing, **THOROUGHLY CLEAN ALL JOINT SURFACES** to prevent contamination.

### Installation of Welded End Valves

(33-SW/43-SW/53-SW OR 33-BW/43-BW/53-BW)

- 1.6. Tack weld the valve on the pipe in 4 points on all end caps.
- 1.7. Remove body bolts, lift out the body with the ball in the open position. Close the ball and remove the seat retainer, ball, and body seals. **Note the position of the seats so that they can be replaced in the same position as they were removed.**
- 1.8. Complete the full welding.
- 1.9. When valve is at ambient temperature, clean all end caps and body surface. Then reassemble with ball, seat retainer, and body seals.
- 1.10. Tighten body bolts evenly in a star pattern; make sure that maximum torque is observed per body bolt torque data. See maintenance for more details.
- 1.11. Check proper operation of the valve before resuming service.

### Installation of Flanged End Valves

(33-F1/43-F1/53-F1 OR 33-F3/43-F3/53-F3)

- 1.12. When installing flanged valves, user must supply flange gasket suitable for the service intended, tighten flange bolts or studs evenly in a star pattern.

### Installation of Hygienic Clamp/Sanitary Ends

(33-SA/43-SA/53-SA OR 33-SF/43-SF/53-SF)

- 1.13. Be sure to consult with supplier of your clamps and gaskets to be used on the hygienic ends for the proper material, pressure rating, and clamp torque for your process. Over torquing clamps may result in damage to the ferrule end.

## OPERATION

### 1. Valve Life

- 1.1. Life of valve can be maximized if the valve is used within the rated range, in accordance with pressure/temperature and corrosion data chart found on our 33, 43, 53-series brochure.

## 2. Manual Operation

- 2.1. A-T Controls Multi-Port Ball valves can be used for 0-90-180-360 degrees by turning the handle based on different flow paths.
- 2.2. Flow path is clearly marked on the stem top.

### Automation Operation

- 2.3. Direct mount of pneumatic or electric actuator to these valves require no brackets and couplings on standard application.  
*Special applications may require the use of a bracket and coupler.*

## !!!WARNING!!!

### MAINTENANCE

A-T Controls Series 33, 43, 53 ball valve has relatively easy maintenance when replacing all parts, even if the valve is installed in the line. By removing all the body bolts, the valve can be removed and the seats, gaskets, ball, and stem can be replaced without disturbing pipe alignment.

**!!CAUTION!!** must be used when repairing valve in line. Proper tag out and lock out procedures must be used. Make sure valve is cooled to ambient temperature and all pressure relieved prior to disassembly.

When rebuilding, a standard repair kit designated for each size and style valve is available, each repair kit contains 5 Seats, 5 Joint Gaskets, 5 Retainer Seals, 1 Set of V-ring Packing, 1 Stem Seal, 1 Gland Bushing, and 1 fluorocarbon O-Ring.

- 1) Before disassembly, be sure to discharge the hazardous media that might be entrapped inside valve cavity.
- 2) Remove bolts on the end caps.
- 3) Remove valves body from pipeline
- 4) Remove body seals, seats retainer, and seats. **Note the position of the seats so that they can be replaced in the same position as they were removed.**
- 5) Remove ball, extreme caution should be taken to avoid damage to the ball. **(Pay close attention to the balls position when removing, so the proper flow path can be achieved after assembly)**
- 6) Remove stem from inside the body. A tap to the top of the stem should loosen it. The thrust washer should come out with the stem.
- 7) Once the stem is removed, extreme caution should be taken when removing the packing. Any scratch on the polished surface caused from a foreign object can cause

leakage around the packing.

- 8) Clean and inspect all components to be sure that they are free from foreign matter and pit marks. Paying particular attention to the areas that must maintain a seal. Areas such as finished diameter on stem, inside pipe end, ball and the packing journal should be free from scratches and pitting.
- 9) Once all components have been cleaned, inspected, and replaced as necessary, the valve can be rebuilt using the factory repair kit recommended.
- 10) Reassemble stem with new stem seals, raise stem thru packing journal. Adjust stem packing to appropriate torque per Table 2.
- 11) Reassemble ball into valve body in the same position as it was removed to ensure proper flow pattern.
- 12) Insert new seats and seals into end caps and blind cover.
- 13) Mount ends on body with bolts by alternating equal adjustment in a star pattern to secure end caps to give proper sealing. Tighten body bolts first to 50% Maximum Bolt Torque of Table 1, then proceed to tighten to the Maximum Body Bolt Torque of Table 1. Uneven force applied to body will cause the seat compression either to be tight or to loose and affect the ball valve performance.
- 14) Reassembly into line following installation procedure.
- 15) Cycle valve several times before resuming service.

**Table 1: Body Bolt Torque**

SIZE	50% Maximum Bolt Torque (in*lbs)	Maximum Bolt Torque (in*lbs)
1/4" – 3/4"	65	130
1" – 1-1/4"	140	280
1-1/2"	200	400
2"	305	610
2-1/2"	455	910
3"	590	1180
4"	700	1400

**Table 2: Stem Nut Torque**

Size	Torque (in*lbs)
1/4" – 1/2"	95
3/4" – 1"	139
1-1/4"	139
1-1/2" – 2-1/2"	208
3" – 4"	278

**Seat Kit & Repair Kit Part Numbers**

Series 33, 43, 53 Seat Kits					
Size	PTFE	RTFE	STFE	TFM-1600	UHMWE
1/4"	33-0025-PTFE	33-0025-RTFE	33-0025-STFE	33-0025-TFM	33-0025-UHMW
3/8"	33-0038-PTFE	33-0038-RTFE	33-0038-STFE	33-0038-TFM	33-0038-UHMW
1/2"	33-0050-PTFE	33-0050-RTFE	33-0050-STFE	33-0050-TFM	33-0050-UHMW
3/4"	33-0075-PTFE	33-0075-RTFE	33-0075-STFE	33-0075-TFM	33-0075-UHMW
1"	33-0100-PTFE	33-0100-RTFE	33-0100-STFE	33-0100-TFM	33-0100-UHMW
1-1/4"	33-0125-PTFE	33-0125-RTFE	33-0125-STFE	33-0125-TFM	33-0125-UHMW
1-1/2"	33-0150-PTFE	33-0150-RTFE	33-0150-STFE	33-0150-TFM	33-0150-UHMW
2"	33-0200-PTFE	33-0200-RTFE	33-0200-STFE	33-0200-TFM	33-0200-UHMW
2-1/2"	33-0250-PTFE	33-0250-RTFE	33-0250-STFE	33-0250-TFM	33-0250-UHMW
3"	33-0300-PTFE	33-0300-RTFE	33-0300-STFE	33-0300-TFM	33-0300-UHMW
4"	33-0400-PTFE	33-0400-RTFE	33-0400-STFE	33-0400-TFM	33-0400-UHMW

Series 33, 43, 53 Repair Kits					
Size	PTFE	RTFE	STFE	TFM-1600	UHMWE
1/4"	33-RK-0025-PTFE	33-RK-0025-RTFE	33-RK-0025-STFE	33-RK-0025-TFM	33-RK-0025-UHMW
3/8"	33-RK-0038-PTFE	33-RK-0038-RTFE	33-RK-0038-STFE	33-RK-0038-TFM	33-RK-0038-UHMW
1/2"	33-RK-0050-PTFE	33-RK-0050-RTFE	33-RK-0050-STFE	33-RK-0050-TFM	33-RK-0050-UHMW
3/4"	33-RK-0075-PTFE	33-RK-0075-RTFE	33-RK-0075-STFE	33-RK-0075-TFM	33-RK-0075-UHMW
1"	33-RK-0100-PTFE	33-RK-0100-RTFE	33-RK-0100-STFE	33-RK-0100-TFM	33-RK-0100-UHMW
1-1/4"	33-RK-0125-PTFE	33-RK-0125-RTFE	33-RK-0125-STFE	33-RK-0125-TFM	33-RK-0125-UHMW
1-1/2"	33-RK-0150-PTFE	33-RK-0150-RTFE	33-RK-0150-STFE	33-RK-0150-TFM	33-RK-0150-UHMW
2"	33-RK-0200-PTFE	33-RK-0200-RTFE	33-RK-0200-STFE	33-RK-0200-TFM	33-RK-0200-UHMW
2-1/2"	33-RK-0250-PTFE	33-RK-0250-RTFE	33-RK-0250-STFE	33-RK-0250-TFM	33-RK-0250-UHMW
3"	33-RK-0300-PTFE	33-RK-0300-RTFE	33-RK-0300-STFE	33-RK-0300-TFM	33-RK-0300-UHMW
4"	33-RK-0400-PTFE	33-RK-0400-RTFE	33-RK-0400-STFE	33-RK-0400-TFM	33-RK-0400-UHMW

\*Repair kit include: 5 Seats, 5 Joint Gaskets, 5 Retainer Seals, 1 Set of V-ring Packing, 1 Stem Seal, 1 Gland Bushing, 1 FKM O-Ring  
**Note:** 1/4"-1-1/4" 1 set of V-ring Packing includes three pieces  
 1-1/2"-4" 1 set of V-ring Packing includes four pieces

Series 33, 43, 53 Body Gasket Kits					
Size	PTFE	RTFE	STFE	TFM-1600	UHMWE
1/4"	33-BG-0025-PTFE	33-BG-0025-RTFE	33-BG-0025-STFE	33-BG-0025-TFM	33-BG-0025-UHMW
3/8"	33-BG-0038-PTFE	33-BG-0038-RTFE	33-BG-0038-STFE	33-BG-0038-TFM	33-BG-0038-UHMW
1/2"	33-BG-0050-PTFE	33-BG-0050-RTFE	33-BG-0050-STFE	33-BG-0050-TFM	33-BG-0050-UHMW
3/4"	33-BG-0075-PTFE	33-BG-0075-RTFE	33-BG-0075-STFE	33-BG-0075-TFM	33-BG-0075-UHMW
1"	33-BG-0100-PTFE	33-BG-0100-RTFE	33-BG-0100-STFE	33-BG-0100-TFM	33-BG-0100-UHMW
1-1/4"	33-BG-0125-PTFE	33-BG-0125-RTFE	33-BG-0125-STFE	33-BG-0125-TFM	33-BG-0125-UHMW
1-1/2"	33-BG-0150-PTFE	33-BG-0150-RTFE	33-BG-0150-STFE	33-BG-0150-TFM	33-BG-0150-UHMW
2"	33-BG-0200-PTFE	33-BG-0200-RTFE	33-BG-0200-STFE	33-BG-0200-TFM	33-BG-0200-UHMW
2-1/2"	33-BG-0250-PTFE	33-BG-0250-RTFE	33-BG-0250-STFE	33-BG-0250-TFM	33-BG-0250-UHMW
3"	33-BG-0300-PTFE	33-BG-0300-RTFE	33-BG-0300-STFE	33-BG-0300-TFM	33-BG-0300-UHMW
4"	33-BG-0400-PTFE	33-BG-0400-RTFE	33-BG-0400-STFE	33-BG-0400-TFM	33-BG-0400-UHMW

\*Body Gasket kit include: 5 Joint Gaskets, 5 Retainer Seals

**Note:** When ordering seats, repair kit, and body gasket kits; All 33, 43, 53 use the same part number for the size.

Make sure to specify size, valve code, valve seat, seal and stem packing materials. Optional components such as ball, stem and handle are also available.

## Materials List

### Bill of Materials 33/43/53 Series

MATERIALS LIST				
NO.	PART NAME	QTY	MATERIAL	MATERIAL
1	BODY	1	ASTM A351 GRADE CF8M <sup>A</sup>	ASTM A216 GRADE WCB
2	END CAP	*	ASTM A351 GRADE CF8M <sup>A</sup>	ASTM A216 GRADE WCB
3	BLIND	*	ASTM A351 GRADE CF8M <sup>A</sup>	ASTM A216 GRADE WCB
4	SEAT RETAINER	5	ASTM A351 GRADE CF8M <sup>A</sup>	ASTM A351 GRADE CF8M
5	BALL	1	1/4" THRU 3/8" ASTM A276 SS316	1/4" THRU 3/8" ASTM A276 SS316
5	BALL	1	1/2" THRU 4" ASTM A351 GRADE CF8M <sup>A</sup>	1/2" THRU 4" ASTM A351 GRADE CF8M
6	SEAT	5	RTFE	RTFE
7	JOINT GASKET	5	PTFE	PTFE
8	STEM SEAL	1	RTFE	RTFE
9	STEM	1	ASTM A276 SS316 <sup>A,B</sup>	ASTM A276 SS316
10	GLAND PACKING	1 SET	PTFE	PTFE
11	CLAND BUSHING	1	AISI 304	AISI 304
12	BELLEVILLE WASHER	2	AISI 301	AISI 301
13	LOCK SADDLE	1	AISI 304	AISI 304
14	STEM NUT	**	AISI 304	AISI 304
15	STEM WASHER	1	AISI 304	AISI 304
16	RETAINER SEAL	5	PTFE	PTFE
17	HANDLE SLEEVE	1	VINYL	VINYL
18	LOCKING DEVICE	1	AISI 304	AISI 304
19	BOLT	20	ASTM A193 GRADE B8	ASTM A193 GRADE B8
20	PIN NUT	1	AISI 304	AISI 304
21	STOP PIN	1	AISI 304	AISI 304
22	O-RING	1***	FKM	FKM
23	LOCKING PLATE	1	AISI 304	AISI 304
24	HANDLE	1	AISI 304	AISI 304
25	HANDLE HUB	1	AISI 304	AISI 304
26	HANDLE NUT	2	AISI 304	AISI 304
27	ANTI-STATIC DEVICE	1	AISI 316	AISI 316
28	WASHER	1	AISI 304	AISI 304
29	TRUNNION BEARING	1	50/50 STFE	50/50 STFE
30	TRUNNION RETAINER	1	AISI 316	AISI 316

\*FOR 33 SERIES: QTY 3 END CAP-A, QTY 2 BLIND  
 \*FOR 43 SERIES: QTY 4 END CAP-A, QTY 1 BLIND  
 \*FOR 53 SERIES: QTY 5 END CAP-A, QTY 0 BLIND  
<sup>A</sup>ASTM A351 GRADE CF8M for 33-SA/43-SA/53-SA VALVES  
<sup>B</sup>FOR 1/4"-2-1/2": QTY 2  
<sup>C</sup>FOR 3"-4": QTY 1  
<sup>D</sup>ASTM A276 SS316 for 33-SA/43-SA/53-SA valves  
<sup>E</sup>SERIES 33-SA/43-SA/53 QTY: 0

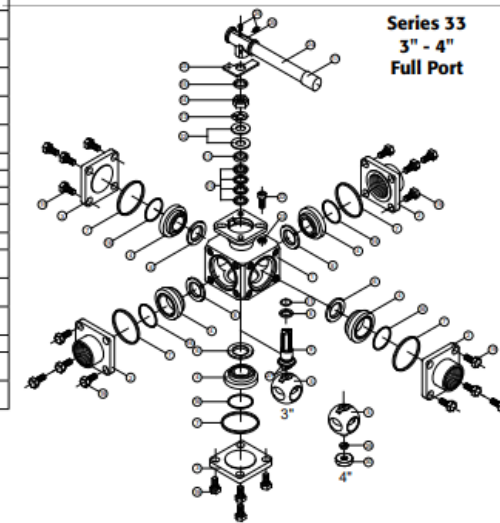
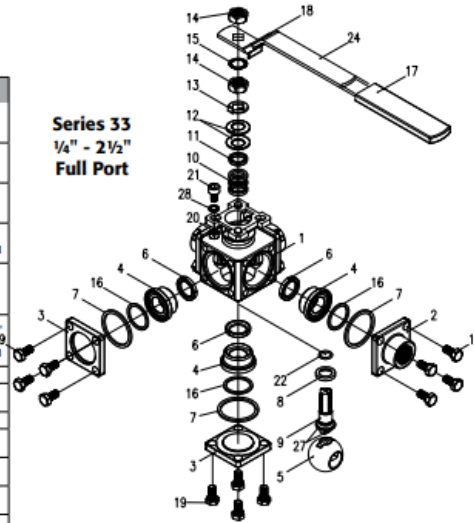

A-T Controls product, when properly selected, is designed to perform its intended function safely during its useful life. However, the purchaser or user of A-T Controls products should be aware that A-T Controls products might be used in numerous applications under a wide variety of industrial service conditions. Although A-T Controls can provide general guidelines, it cannot provide specific data and warnings for all possible applications. The purchaser / user must therefore assume the ultimate responsibility for the proper sizing and selection, installation, operation, and maintenance of A-T Controls products. The user should read and understand the installation operation maintenance (IOM) instructions included with the product, and train its employees and contractors in the safe use of A-T Controls products in connection with the specific application.

While the information and specifications contained in this literature are believed to be accurate, they are supplied for informative purposes only. Because A-T Controls is continually improving and upgrading its product design, the specifications, dimensions and information contained in this literature are subject to change without notice. Should any question arise concerning these specifications, the purchaser/user should contact A-T Controls.

For product specifications go to <https://a-tcontrols.com/downloads/>

A-T Controls, Inc. • 9955 International Boulevard, Cincinnati, OH 45246 • Phone: (513) 530-5175 • Fax: (513) 247-5462 • [www.a-tcontrols.com](http://www.a-tcontrols.com)