

Contents

1. SCOPE	2
2. INSTALLATION	2
3. VALVE OPERATION	2
4. DISASSEMBLY	3
5. ASSEMBLY	4
6. ATTENUATOR ASSEMBLY	5
7. REPAIR KITS	5
8. BILL OF MATERIALS.....	6

1. SCOPE

1.1. CAUTION

- 1.1.1. For your safety, read this manual before installation or service.
- 1.1.2. Before installing or servicing, please ensure the line pressure has been relieved and any hazardous fluids have been drained or purged from the system.
- 1.1.3. Ensure that all Lockout and Tagout procedures for the system have been properly implemented.

1.2. USE

- 1.2.1. Maximum results and long life of valves can be maintained under normal working conditions and according with pressure/ temperature ratings and corrosion data chart.

2. INSTALLATION

2.1. GENERAL INFORMATION FOR INSTALLATION

- 2.1.1. The valve can be installed in any position on the pipeline.
- 2.1.2. Before installation of the valve, the pipe must be flushed clean of dirt, burrs, and welding residue, or the seat and segment surface will be damaged. The pipe must be free from tension and in proper alignment. Check to ensure that all connections are free from defects.

2.2. INSTALLATION OF FLANGED ENDS

- 2.2.1. Carefully align gaskets on each end of the valve and insert the valve into the pipeline. Ensure that bolt holes on the valve line up with bolt holes on the pipeline. Insert flange bolts and nuts on the ends of the valve and tighten evenly in a star pattern. Please consult with your gasket manufacturer for the proper torque of the flange bolts.

2.3. INSTALLATION OF WAFER ENDS

- 2.3.1. Carefully align gaskets on each end of the valve and insert the valve into the pipeline. Ensure that the bolt holes on the valve line up with the bolt holes on the pipeline. Insert studs and nuts on the ends of the valve and tighten the nuts evenly in a star pattern. Please consult with your gasket manufacturer for the proper torque of the studs.

3. VALVE OPERATION

3.1. MANUAL

3.1.1. GEAR

- 3.1.1.1. To OPEN the valve, turn the hand wheel counterclockwise. The indicator will be pointing to the open position and the hand wheel will stop rotating when fully opened. The flow can be adjusted by stopping the indicator anywhere between open and close.
- 3.1.1.2. To CLOSE the valve, turn the hand wheel clockwise. The indicator will be pointing to the close position and the hand wheel will stop rotating when fully closed. The flow can be adjusted by stopping the indicator anywhere between open and close.

3.2. AUTOMATED

3.2.1.A-T Controls V-Segment Series Ball Valves can be mounted with quarter turn actuators. Valves with actuators shall be checked for proper valve stem alignment. Angular or linear misalignment may result in high operational torque and unnecessary wear on the valve stem. See the actuator IOM for information on operating the actuator.

4. DISASSEMBLY

!!! WARNING !!!

CAUTION, FLUIDS CAN BE TRAPPED IN THE BODY OF THE VALVE, POSSIBLY UNDER HIGH PRESSURE. FOR YOUR SAFETY, IT IS IMPORTANT THAT PRECAUTIONS ARE TAKEN BEFORE REMOVAL OF THE VALVE FROM THE LINE OR ANY DISASSEMBLY.

For Soft-Seated Type

- 4.1. Remove actuator or gear if equipped.
- 4.2. Care should be taken to not damage the surface finish of the valve components.
- 4.3. Relieve line pressure and flush to remove any hazardous materials. Allow temperature in pipeline and valve to cool to a temperature safe for handling.
- 4.4. Remove valve from pipeline.
- 4.5. Turn the valve to the CLOSED position.
- 4.6. Loosen the bolts (8), remove the cap (7), and seat (6A) from the body (1).
- 4.7. Remove the gland bolts (14), then remove the gland (13). Remove the lower cover bolts (17) and the end cover (5).

CAUTION: BEFORE REMOVING THE STEM (3) AND SHAFT (4), ENSURE THAT THE SEGMENT (2) IS NOT GOING TO FALL OUT OF THE VALVE AND BE DAMAGED.

- 4.8. Remove the c-clip (21), then remove the stem (3) and shaft (4) carefully while supporting the segment.
- 4.9. Remove the gland packing (12) being careful not to scratch or damage gland bore. Remove washers (10, 11) and upper thrust bushing (9).
- 4.10. Remove cover gasket (16) again being careful not to scratch the surface. Remove lower thrust bushing (9) and support bushing (15).
- 4.11. Carefully clean and inspect all parts for wear and damage. Ensure that all gasket and packing residue is thoroughly cleaned before valve is reassembled. All soft parts should be replaced.

For Metal-Seated Type

- 4.12. Remove Actuator or gear if equipped.
- 4.13. Care should be taken to not damage the surface finish of the valve components.
- 4.14. Relieve the line pressure and flush to remove any hazardous materials. Allow temperature in pipeline and valve to cool to a temperature safe for handling.
- 4.15. Turn the valve to the closed position.
- 4.16. Remove the valve from the pipeline.

- 4.17. Loosen the bolts (8), remove the cap (7), spring (6F), seat gland (6E), packing (6D), and seat support (6B) from body (1).
- 4.18. Remove gland bolts (14) then remove the gland (13). Remove the lower cover bolts (17) and the end cover (5).
CAUTION: BEFORE REMOVING STEM (3) AND SHAFT (4) ENSURE THAT SEGMENT (2) IS NOT GOING TO FALL OUT OF THE VALVE AND BE DAMAGED.
- 4.19. Remove the c-clip (21), then remove stem (3) and shaft (4) carefully while supporting the segment (2).
- 4.20. Remove the gland packing (12) being careful not to scratch or damage the gland bore. Remove washers (10, 11) and upper thrust bushing (9).
- 4.21. Remove cover gasket (16) again being careful to not scratch the surface. Remove lower thrust bushing (9) and support bushing (15).
- 4.22. Carefully clean and inspect all parts for wear and damage. Ensure all gasket and packing residue is thoroughly cleaned before valve is reassembled. All soft parts should be replaced.

5. ASSEMBLY

For Soft-Seated Type

- 5.1. Install upper thrust bushing (9) and lower support bushing (15) along with lower thrust bushing (9).
- 5.2. Carefully support segment (2) in housing while inserting stem (3) and shaft (4) into body (1) and into segment (2).
- 5.3. Insert c-clip (21).
- 5.4. Install cover gasket (16) and end cover (5) then secure with cover bolts (17).
- 5.5. Install washers (10, 11) then carefully install gland packing (12).
- 5.6. Install gland (13) and secure with gland bolts (14).
- 5.7. The segment should be in the closed position as shown below in **Figure 1** before installing the seat (6) and cover (5).

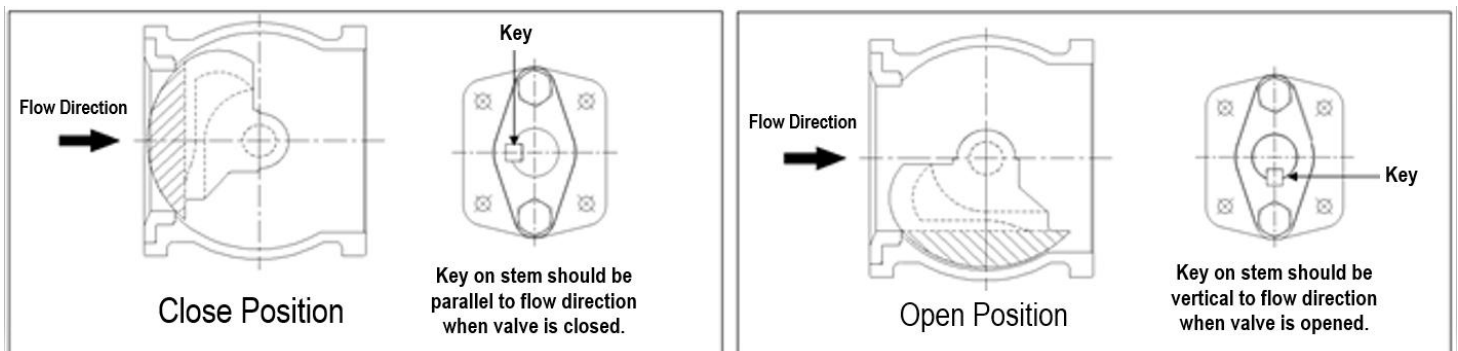

Figure 1

- 5.8. Insert the seat (6A) and end cover (5) into the body (1).
- 5.9. Tighten cover bolts (17) and bolts (8) in a star pattern with even strength. Tighten gland bolts (14).
- 5.10. Check that valve is assembled correctly and in the CLOSED position.

For Metal-Seated Type

- 5.11.
- 5.12. Install upper thrust bushing (9) and lower support bushing (15) along with lower thrust bushing (9).

- 5.13. Carefully support segment (2) in housing while inserting stem (3), and shaft (4) into body (1) and into segment (2).
- 5.14. Insert c-clip (21).
- 5.15. Install cover gasket (16) and end cover (5) then secure with cover bolts (17).
- 5.16. Install washers (10, 11) then carefully install gland packing (12).
- 5.17. Install gland (13) and secure with gland bolts (14).
- 5.18. Insert the seat support (6B), seat (6C), packing (6D), seat gland (6E), spring (6F), and cap into the body (1).
- 5.19. Tighten cover bolts (17) and bolts (8) evenly in a star pattern. Tighten gland bolts (14).
- 5.20. Check that valve is assembled correctly and in the CLOSED position.

6. ATTENUATOR ASSEMBLY

- 6.1. Turn valve to the CLOSED position.
- 6.2. Loosen the bolts (8) and cap (7). These do not need to be completely removed.
- 6.3. Remove gland bolts (14) then remove gland (13). Remove the lower cover bolts (17) and the end cover (5).
CAUTION: BEFORE REMOVING STEM (3) AND SHAFT (4), ENSURE THAT THE SEGMENT (2) IS NOT GOING TO FALL OUT OF THE VALVE AND BE DAMAGED.
- 6.4. Remove c-clip (21), stem (3) and shaft (4) carefully while supporting the segment (2).
- 6.5. Attenuator (22) assembly will include replacement support bushing (15) **or** replacement shaft (4).
 - 6.5.1. **Sizes up to 2"** include replacement support bushing (15). The segment (2) will need to be removed in order to remove and replace the original support bushing (15).
 - 6.5.1.1. When inserting replacement support bushing (15), insert only to inner surface of segment (2) to allow room to install attenuator (22).
 - 6.5.2. **Sizes larger than 2"** include a replacement shaft (4), the segment (2) remains within the body (1). New shaft (4) will replace original shaft (4).
- 6.6. Place attenuator (22) into the segment (2).
 - 6.6.1. For sizes up to 2", insert support bushing (15) fully into attenuator (22), flush with the outer surface of the segment (2).
- 6.7. Tighten attenuator bolt (23).
- 6.8. Insert stem (3) into body (1) and segment (2) while maintaining correct position as shown in **Figure 1**. Insert shaft (4) into body (1) and segment (2).
- 6.9. Install cover gasket (16) and end cover (5) then secure with cover bolts (17).
- 6.10. Install gland (13) and secure with gland bolts (14).
- 6.11. Install end cover (5) into the body (1).
- 6.12. Tighten cover bolts (17) and bolts (8) evenly in star pattern. Tighten gland bolts (14).

7. REPAIR KITS

Repair kits are available to replace all soft goods. See Bill of Materials for components that are included in the repair kits.

8. BILL OF MATERIALS

VS SERIES SEGMENT 50/50 SEAT - 400 Deg F			
NO.	PART NAME	QTY	REPAIR KIT
1	BODY	1	
2.1	SEGMENT	1	
3	STEM	1	
4	SHAFT	1	
5	END COVER	1	
6A	SOFT SEAT	1	X
7	CAP	1	
8	BOLT	*	
9	THRUST BUSHING	2	
10	WASHER	1	X
11	WASHER	1	X
12	GLAND PACKING	1	X
13	GLAND	1	
14	GLAND BOLT	2	
15	SUPPORT BUSHING	1	
16	COVER GASKET	1	X
17	COVER BOLT	4	
18	STEM O-RING	1	X
19	WASHER	1	X
20	WASHER	1	X
21	C-CLIP	1	
22	ATTENUATOR	1	
23	ATTENUATOR BOLT	1	
* Vary with size			

VV Metal Seat- VITON Seat Packing - 500 Deg F			
NO.	PART NAME	QTY	REPAIR KIT
1	BODY	1	
2	SEGMENT	1	
3	STEM	1	
4	SHAFT	1	
5	END COVER	1	
6G	SEAT	1	
6H	O-RING	1	
6I	SPRING	1	
7	CAP	1	
8	BOLT	*	
9	THRUST BUSHING	2	
10	WASHER	1	X
11	WASHER	1	X
12	GLAND PACKING	1	X
13	GLAND	1	
14	GLAND BOLT	2	
15	SUPPORT BUSHING	1	
16	COVER GASKET	1	X
17	COVER BOLT	4	
18	STEM O-RING	1	X
19	WASHER	1	X
20	WASHER	1	X
21	C-CLIP	1	
22	ATTENUATOR	1	
23	ATTENUATOR BOLT	1	
*Vary with size			

VM Metal Seat - Graphite Seat Packing - 600 Deg F			
NO.	PART NAME	QTY	REPAIR KIT
1	BODY	1	
2.2	SEGMENT	1	
3	STEM	1	
4	SHAFT	1	
5	END COVER	1	
6B	SEAT SUPPORT	1	
6C	SEAT	1	
6D	PACKING	1	
6E	SEAT GLAND	1	
6F	SPRING	1	
7	CAP	1	
8	BOLT	*	
9	THRUST BUSHING	2	
10	WASHER	1	X
11	WASHER	1	X
12	GLAND PACKING	1	X
13	GLAND	1	
14	GLAND BOLT	2	
15	SUPPORT BUSHING	1	
16	COVER GASKET	1	X
17	COVER BOLT	4	
18	STEM O-RING	1	X
19	WASHER	1	X
20	WASHER	1	X
21	C-CLIP	1	
22	ATTENUATOR	1	
23	ATTENUATOR BOLT	1	
* Vary with size			

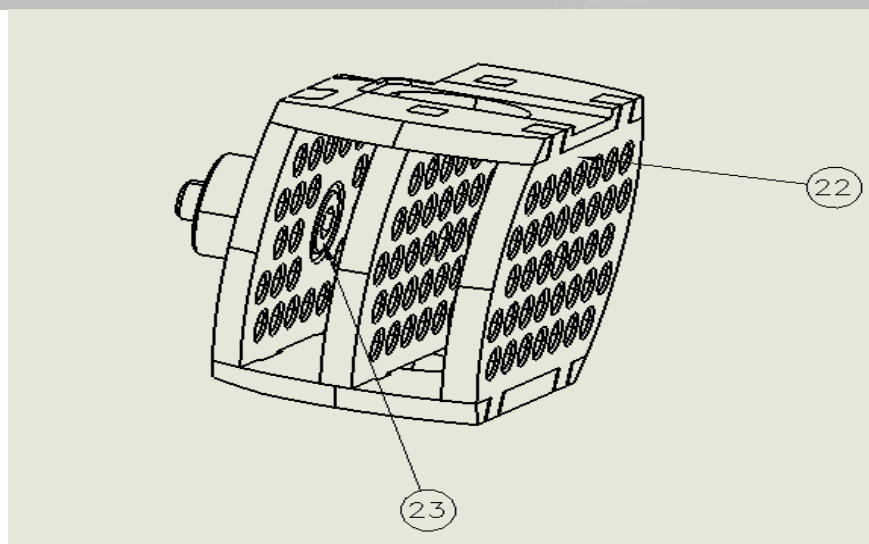
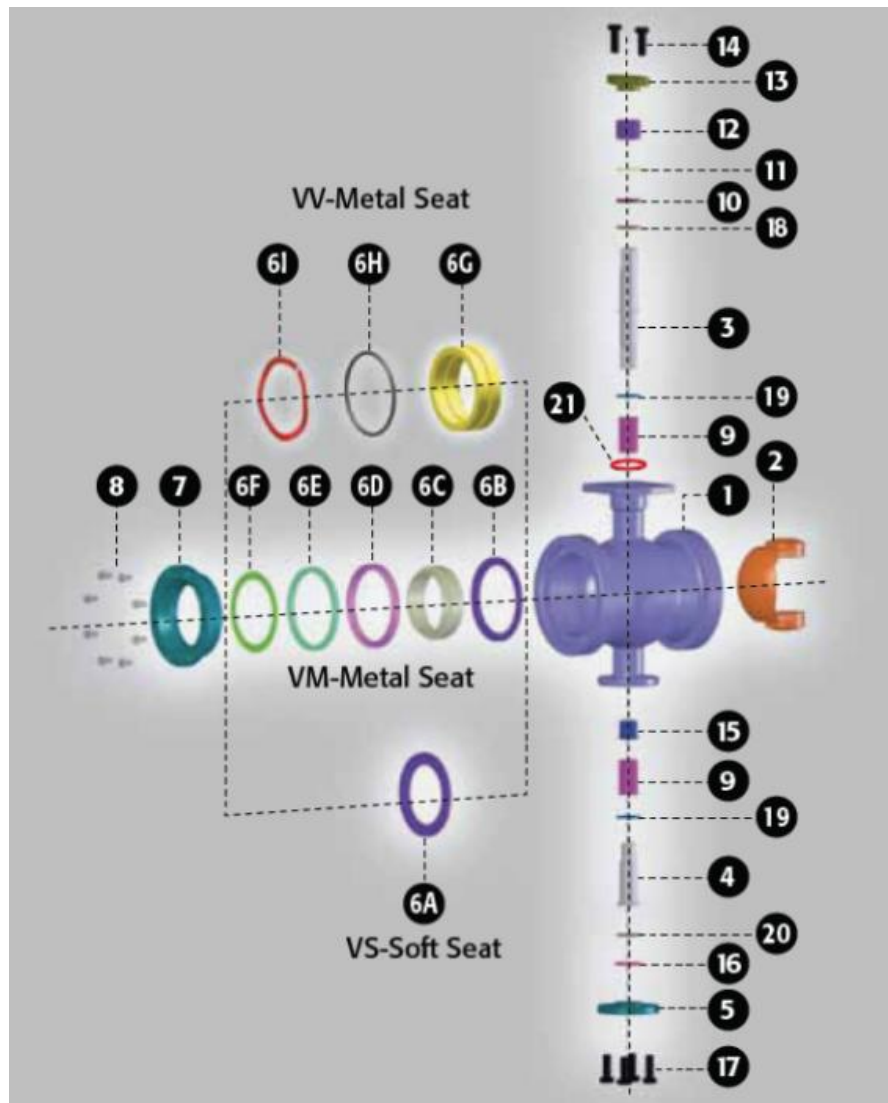

A-T Controls product, when properly selected, is designed to perform its intended function safely during its useful life. However, the purchaser or user of A-T Controls products should be aware that A-T Controls products might be used in numerous applications under a wide variety of industrial service conditions. Although A-T Controls can provide general guidelines, it cannot provide specific data and warnings for all possible applications. The purchaser / user must therefore assume the ultimate responsibility for the proper sizing and selection, installation, operation, and maintenance of A-T Controls products. The user should read and understand the installation operation maintenance (IOM) instructions included with the product and train its employees and contractors in the safe use of A-T Controls products in connection with the specific application.

While the information and specifications contained in this literature are believed to be accurate, they are supplied for informative purposes only. Because A-T Controls is continually improving and upgrading its product design, the specifications, dimensions and information contained in this literature are subject to change without notice. Should any question arise concerning these specifications, the purchaser/user should contact A-T Controls.

For product specifications go to <https://a-tcontrols.com/Downloads/> A-T Controls, Inc. • 9955 International Boulevard, Cincinnati, OH 45246 • Phone: (513) 530-5175 • Fax: (513) 247-5462 • www.atcontrols.com